

SYMBOL DEFINITION	
A DIMENSION WITHOUT AN INSPECTION REPORT SYMBOL  DOES NOT REQUIRE INSPECTION. IT MAY BE CONTROLLED ON THE INDIVIDUAL COMPONENT DRAWING.	TOTAL NO OF INSPECTIONS REQUIRED
	36
	LAST NO. USED
	15

MISSING SYMBOLS					DWG STATUS					REVISION HISTORY			AUTH	DR	APVD1	APVD2
DATE	STG	REV	N/P	CHG	ZONE	DATE	STG	REV	N/P	CHG	ZONE	DATE	STG	REV	N/P	CHG
25MY04	R	01	-	-		255795	JBD	JAA	MGR			255795	JBD	JAA	MGR	
26AP05	R	01	AA	-		266520	JTV	FKV	MGR			266520	JTV	FKV	MGR	

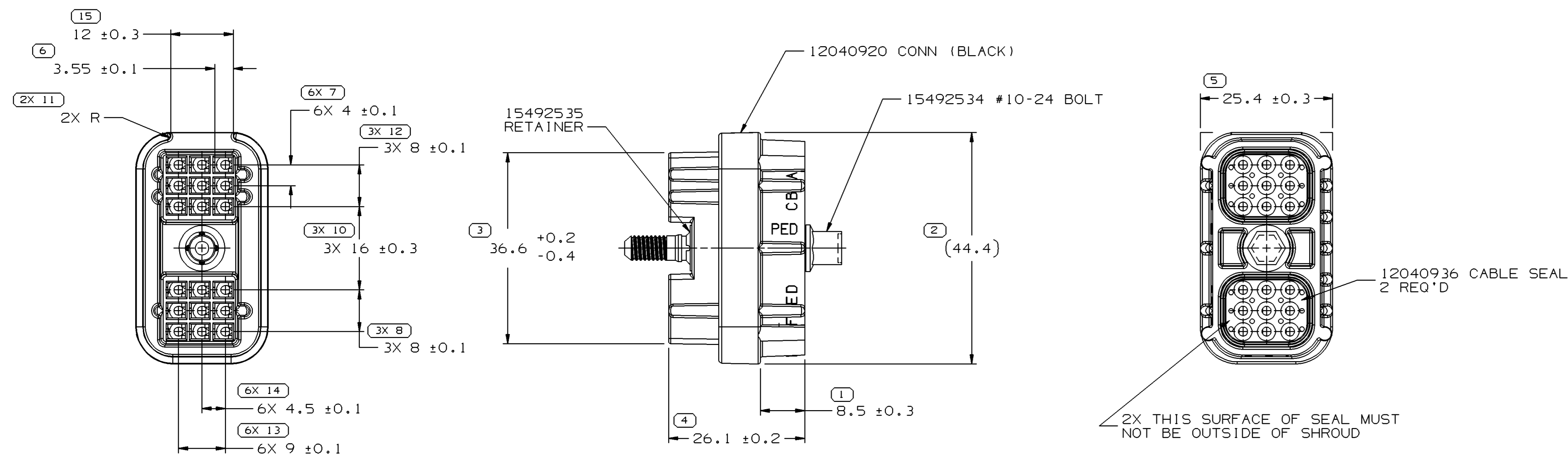

- NOTES
- UNLESS OTHERWISE SPECIFIED AND/OR INDICATED: DIMENSIONS ARE TO FACE OF VIEW SHOWN AND AUTOMATICALLY ROUNDED BY COMPUTER FOR INSPECTION (SEE MATH MODEL FOR PRECISE DIMENSIONS). FOR ALL OTHER DIMENSIONS NOT SHOWN BUT REQUIRED FOR TOOL BUILD, SEE MATH MODEL FOR PRECISE TOOL PATH DATA.
 - THIS PART ACCEPTS THE FOLLOWING COMPONENTS OR EQUIVALENT: CAVITIES TO ACCEPT 12047680 TERMINAL OR EQUIVALENT.
 - REFERENCE MATING COMPONENTS OR EQUIVALENT: CONNECTOR 12040923
 - THIS PART IS NOT CONTROLLED FOR AUTOMATIC FEEDING.
 - BOLT TO BE RETAINED TO A MINIMUM 400 N FORCE.
 - CONNECTOR TO BE ASSEMBLED TO MATING CONNECTOR WITH A TORQUE OF 0.8 N-M TO 1.5 N-M.
 - BOLT MUST ROTATE IN CONNECTOR AT A TORQUE OF LESS THAN 0.6 N-M (5.3 INCH-POUNDS) AFTER RETAINER IS ASSEMBLED.
 - SEALING CODE 3 - DESIGN WILL PASS SALT FOG AND IMMERSION TEST AFTER CONDITIONING AS SPECIFIED IN ESA-644 (WEATHER-PACK), ESA-710 (METRI-PACK), ESA-650 (UNDERHOOD MICRO-PACK), C-4006 (WORLD CONNECTOR), ETC WHEN MATED TO MATING PART OR EQUIVALENT

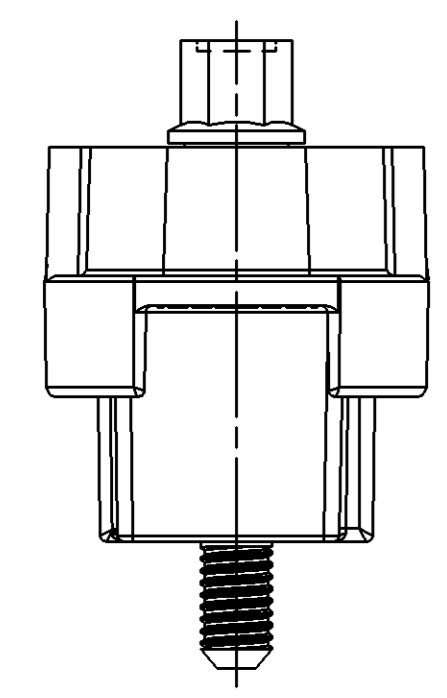
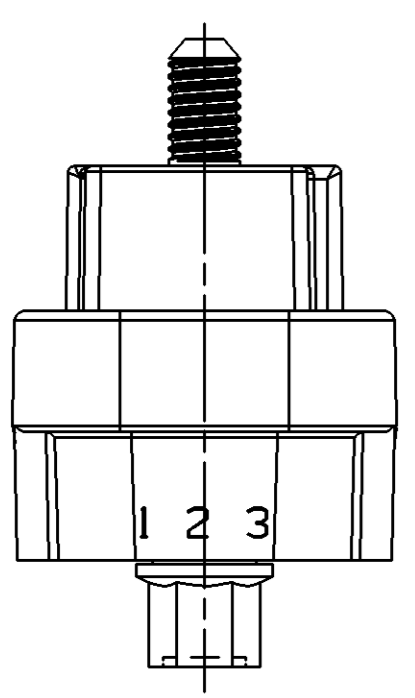
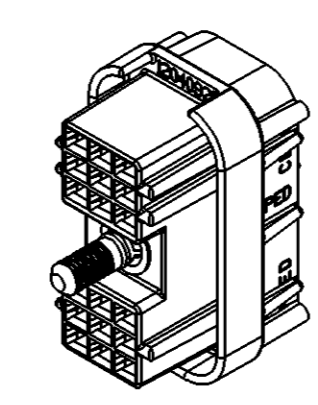

DIMENSIONAL RANGE (MM)		CHART E1	
FROM	TO	TOLERANCE	CHART E1
> 0	> 20	±0.15	1
> 20	> 30	±0.2	2
> 30	> 70	±0.3	3
> 70	> 100	±0.4	4
> 100	> 150	±0.5	5
> 150	> 200	±0.6	6
> 200	> 250	±0.8	7
> 250	> 300	±1	8
> 300	> 400	±1.2	9

TOLERANCE UNLESS OTHERWISE SPECIFIED

ANGULAR TOLERANCE ±2°

DWG TYPE: PART DRAWING

STYLE: _____

VOLUME (CM³): _____

DISTR CODE: **D**

UNLESS OTHERWISE SPECIFIED

THIS DOCUMENT IS IN ACCORDANCE WITH ASME Y14.5M-1994 AS AMENDED BY THE GM GLOBAL DIMENSIONING AND TOLERANCING ADDENDUM-2001. SEPARATE PATTERNS OF FEATURES MAY BE GAGED SEPARATELY REGARDLESS OF DATUM REFERENCES.

ALL DIMENSIONS ARE IN MILLIMETERS

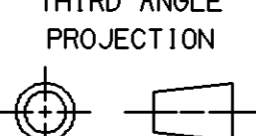
RENDERING: 

DO NOT SCALE

UNIGRAPHICS

DELPHI

DELPHI PACKARD ELECTRIC SYSTEMS
WARREN, OH

DR	DATE
APVD1 JOSE R. BARRIENTOS	06JL04
APVD2 J. S. ALVARADO	12AU04
APVD3 MATTHEW ROUSSEL	18AU04
APVD4	
APVD5	

SUBSTANCES OF CONCERN AND RECYCLED CONTENT PER DELPHI 10949001

MATERIAL SEE DRAWING

DRAWING NAME: ASM CONN 18 F M/P 150 BLK SLD

DRAWING NUMBER: 15492546

SIZE	SCALE	FRAME NO	SHEET NO	STG	REV	N/P	AA
A1	2:1	1 OF 1	1 OF 1	R	01	AA	